

# 30" x 20.5" Bolt Plate Truss

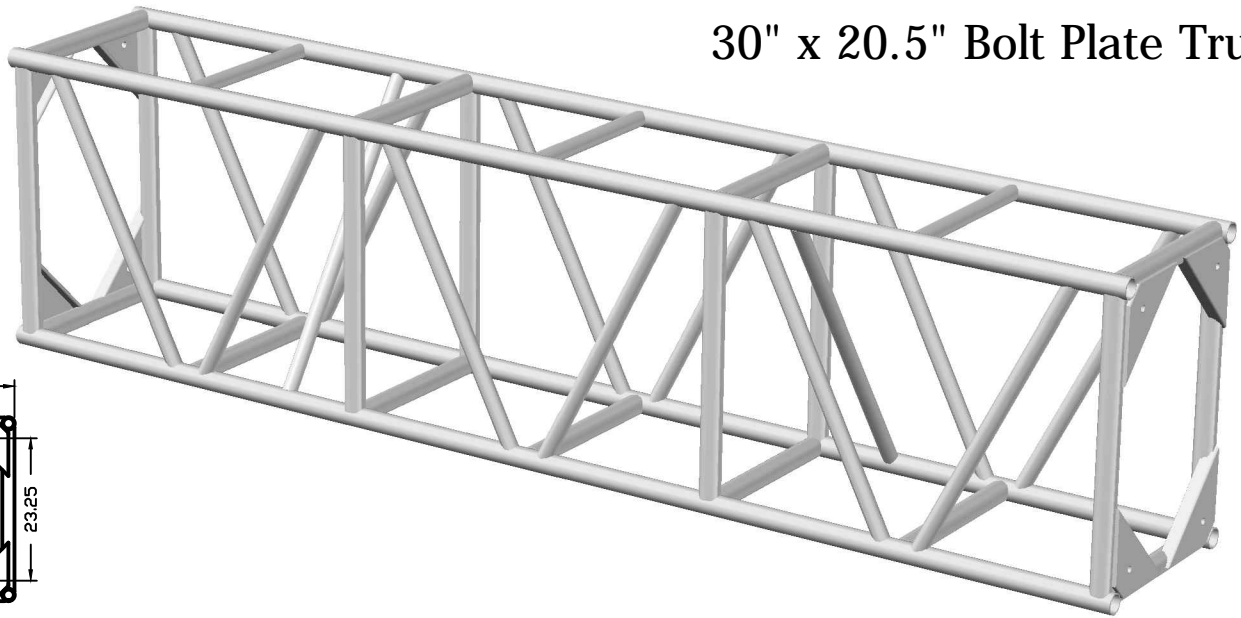
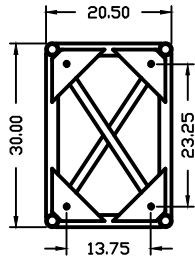

## Reliable Design Services - 30"x20.5" Bolt Plate Connected Truss Maximum Allowable Superimposed Gravity Loads

Span (ft)	Uniformly Distributed			Center Point Loads		Third Point Loads		Quarter Point Loads		Fifth Point Loads	
	UDL (plf)	Total Load (lbs)	Max Defl. (in)	Load (lbs)	Max Defl. (in)	Load (lbs)	Max Defl. (in)	Load (lbs)	Max Defl. (in)	Load (lbs)	Max Defl. (in)
5	3772	18858	0.01	1 @ 17192	0.01	2 @ 9429	0.01	3 @ 6286	0.01	4 @ 4714	0.01
10	1710	17098	0.07	1 @ 8549	0.05	2 @ 6418	0.07	3 @ 4275	0.06	4 @ 3562	0.07
15	753	11295	0.15	1 @ 5647	0.12	2 @ 4240	0.15	3 @ 2824	0.14	4 @ 2353	0.15
20	418	8362	0.27	1 @ 4181	0.21	2 @ 3139	0.27	3 @ 2090	0.25	4 @ 1742	0.27
25	263	6577	0.41	1 @ 3288	0.33	2 @ 2469	0.42	3 @ 1644	0.40	4 @ 1370	0.42
30	179	5366	0.60	1 @ 2683	0.48	2 @ 2014	0.61	3 @ 1342	0.57	4 @ 1118	0.60
35	128	4483	0.81	1 @ 2242	0.66	2 @ 1683	0.83	3 @ 1121	0.78	4 @ 934	0.82
40	95	3806	1.06	1 @ 1903	0.87	2 @ 1429	1.08	3 @ 951	1.02	4 @ 793	1.07
45	73	3265	1.34	1 @ 1632	1.11	2 @ 1226	1.37	3 @ 816	1.29	4 @ 680	1.35
50	56	2820	1.66	1 @ 1410	1.39	2 @ 1058	1.69	3 @ 705	1.59	4 @ 587	1.67
55	44	2444	2.01	1 @ 1222	1.69	2 @ 917	2.04	3 @ 611	1.93	4 @ 509	2.02
60	35	2121	2.39	1 @ 1060	2.03	2 @ 796	2.43	3 @ 530	2.30	4 @ 442	2.40

**Notes:**

1. The following abbreviations have been utilized in the above table:

- UDL            Uniformly Distributed Load
- Calc. Defl.    Calculated Deflection
- plf            Pounds Per Lineal Foot
- ft             Feet
- lbs            Pounds
- in             Inches

2. The loads outlined in the above table are for the Reliable Design Services 30"x20.5" Plate Connected Truss. This truss has 2" diameter x 1/8" thick aluminum chords, 2" x 1" x 1/8" thick aluminum end members, 2" diameter x 1/8" bottom horizontals, and 1 1/2" diameter x 1/8" thick aluminum diagonals.
3. The Uniformly Distributed Load is only allowable if it is truly distributed uniformly across the span of the truss.
4. The Center Point Loads reported are the maximum allowable point loads applied at the center of a span of this truss.
5. The Third Point Loads reported are the maximum allowable point loads applied at each third point along a span of this truss.
6. The Quarter Point Loads reported are the maximum allowable point loads applied at each quarter point along a span of this truss.
7. The Fifth Point Loads reported are the maximum allowable point loads applied at each fifth point along a span of this truss.
8. The self weight of the truss has been taken into account in the preparation of this load table. Therefore, the user need not subtract the weight of the truss from the provided loads.
9. The loads tabulated above only include static (non-moving) loads. Dynamic (moving) or shock loads have not been considered.
10. Lateral (sideways) loads have not been considered in the calculations of the loads tabulated above. The truss has no diagonals in the bottom face and should not be laterally loaded.
11. Seismic and wind loads have not been considered in the calculations of the loads tabulated above.
12. The deflections tabulated above are based upon connections allowing no movement. Due to clearances required to assemble the multiple trusses into a single span, actual deflections may be slightly higher than the tabulated values.
13. This table was prepared by Michael Lea Enterprises, Fort Worth, Texas, 76126, 817-454-8032.



(972) 584-0551 [WWW.RDS-WEB.COM](http://WWW.RDS-WEB.COM)

### Standard Part #'s and weights (Custom lengths available)

10' Section	PN# - BP30x20x120	105 LBS	2-Way Corner	PN# - BP3020-CB2	32 LBS
8' Section	PN# - BP30x20x96	83 LBS	3-Way Corner	PN# - BP3020-CB3	39 LBS
5' Section	PN# - BP30x20x60	54 LBS	4-Way Corner	PN# - BP3020-CB4	46 LBS